

COMPANION CART PORTABLE CLEANING SYSTEM

DESCRIPTION

Stoelting's Companion Cart Portable Cleaning System allows ease of cleaning your Frozen Treat machine acting as if you had a three sink system. It is fully customizable so you can get the exact configuration that suits your cleaning needs based upon your machine location and application.

The Companion Cart 3 allows for cleaning without needing to breakdown the equipment to clean and maintain your fresh Frozen Treat machine. This saves labor, time, and money for your business.

Whether you serve soft serve, yogurt, shake or smoothie, frozen custard, or frozen beverage, the Companion Cart is the cleaning accessory to meet your business needs.



Every machine includes Stoelting's White Glove Service. One call does it all – customer service, technical service, parts or warranty information, installation, startup, sales, on-site service dispatch and much more. Available 24 hours a day, seven days a week year-round.

Continuous research leads to ongoing product improvements; therefore, these specifications are subject to change without notice and should not be used as installation specifications.

ITEMS

- CIPCART-1** Direct Connect to Water Supply
- CIPCART-2** Self-Contained with Pump
- CIPCART-3F3** Self-Contained with Pump and Hydra Rinse System

ACCESSORIES & OPTIONS

- 265002** Hydra Rinse™ All-Purpose Wipes
- 265003** LEXX™ Liquid Sanitizer and Cleaner Concentrate (1 Gallon)
- 265004** LEXX™ Liquid Sanitizer and Cleaner Concentrate Cups (Case 72)
- 2208671-1** Hydra Rinse™ Pro-Control Wall Bracket
- 2208610** Hydra Rinse™ Kit for U431 Units
- 2208604** Hydra Rinse™ Kit for F231 Units
- 2208667** Hydra Rinse™ Kit for U421 Units
- 2209005** Hydra Rinse™ Kit for Auto-Dispense Units

FEATURES
Companion Cart 1

- Modular design for easy disassemble, transport and reassemble.
- The hose connects directly to the water supply (CIPCART-1 only).
- Fifty foot hose is safe for potable water.
- On-board 15-gallon gray water tank means fewer trips to empty the tank, saving time and labor.
- Spray wand with adjustable flow rate creates an easier and more efficient sanitizing process.
- Built-in holders for hose, paper towel, and sanitizing wipes (included).
- Extendable drain board provides additional counter space.
- Caster wheels, two lock.

Companion Cart 2

All features of Companion Cart 1 plus the following

- On-board 15-gallon freshwater and 15-gallon gray water tanks enable use of the cart without an external water connection.
- The 12V SLA battery-powered water pump provides up to three hours of regular use and recharges in about two hours.
- Integrated Hydra Rinse™ sanitizing and washing system includes a spray wand with coiled hose that connects to LEXX™ liquid sanitizer and cleaner concentrate (included).
- Dial controls enable switching between water or LEXX™ delivery.
- Recommended sanitizing products are environmentally friendly, meet FDA requirements for medical devices, and are certified by the EPA as a hospital grade disinfectant when used with a disinfecting wand (sold separately). Please consult the sanitizing products documentation for instructions.
- Foldable faucet for easy storage.
- Folding step stool, rated for 250 lbs., conveniently stows on cart.
- 6 ft. (183 cm) battery charger cord.

Companion Cart 3

All features of Companion Cart 2 plus the following

- Hydra Rinse system mixer unit connects directly to the front door of the Frozen Treat machine and controls the cleaning and sanitizing process.

Approvals
Date

--	--

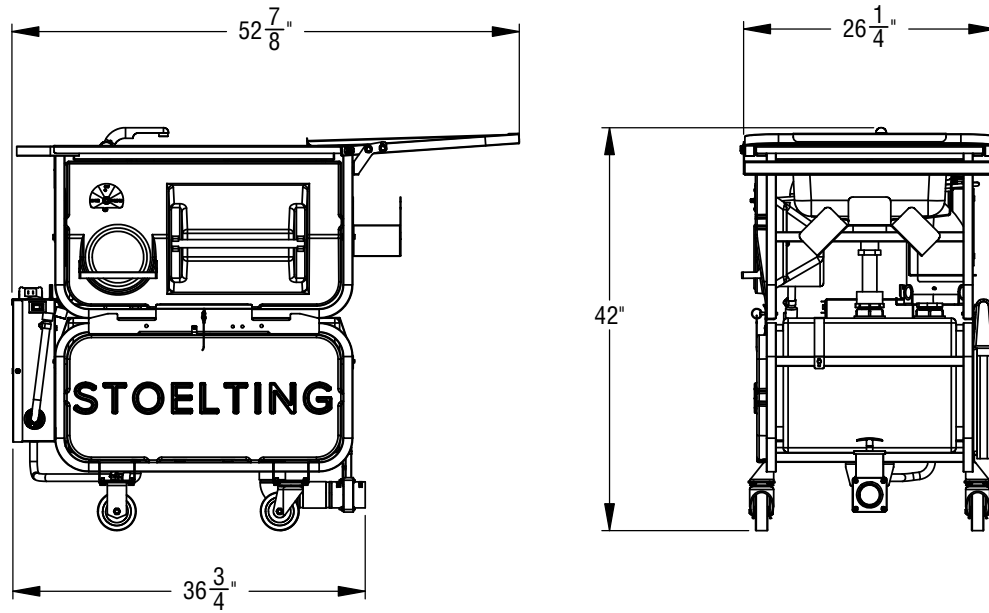
COMPANION CART PORTABLE CLEANING SYSTEM**DIMENSIONS****GENERAL SPECIFICATIONS**

Model	Fresh Water Tank gallons	Waste Water Tank gallons	Waste Water Outlet	Weight lb (kg)	Crated Weight lb (kg)
CIPCART-1	N/A	15	2" N.P.T.	114 (51.7)	150 (68.0)
CIPCART-2	15	15	2" N.P.T.	136 (61.7)	172 (78.0)
CIPCART-3F3	15	15	2" N.P.T.	152 (68.9)	210 (95.3)

- Weight is without the water tanks filled.
- Battery charger for CIPCART-2 and CIPCART-3F3 has a 6' cord with a NEMA 5-15P plug.

UPGRADE KITS

The Companion Cart Portable Cleaning Systems can be customized for your specific needs.

Upgrade Kit	CIPCART-1	CIPCART-2	CIPCART-3
Fresh water tank 15 Gallons	Upgrade	Standard	Standard
Foldable faucet for easy storage	Upgrade	Standard	Standard
Water pump system (includes pump, battery, and charger)	Upgrade	Standard	Standard
Folding step stool (includes mounting bracket)	Upgrade	Standard	Standard
Hydra Rinse wand system	Upgrade	Standard	Standard
Hydra Rinse system mixer	Upgrade	Upgrade	Standard



Service Information
 800-319-9549 (U.S. Toll Free)
 920-894-2293 (Outside the U.S.)
 www.stoeltingfoodservice.com
 www.vollrath.com