

CC202A, CC303A CONTINUOUS FLOW FROZEN CUSTARD FLOOR MACHINES

CC202A

CC303A

DESCRIPTION

Double, and triple barrel continuous flow freezers produce frozen custard, sorbet, Italian ices and other frozen desserts. The patented freezing chamber minimizes the size of ice crystals for a smoother, creamier product. Match production to demand with the “hold product” mode refrigeration setting.



Every machine includes Stoelting's White Glove Service. One call does it all – customer service, technical service, parts or warranty information, installation, startup, sales, on-site service dispatch and much more. Available 24 hours a day, seven days a week year-round.

ITEMS

- CC202-109A00SIR** Water-Cooled, Three Phase
- CC202-18A00SIR** Water-Cooled, Single Phase
- CC202-209A00SIR** Remote Air-Cooled, Three Phase
- CC202-28A00SIR** Remote Air-Cooled, Single Phase
- CC303-109A00SIR** Water-Cooled, Three Phase
- CC303-209A00SIR** Remote Air-Cooled, Three Phase
- CC303-28A00SIR** Remote Air-Cooled, Single Phase

ACCESSORIES & OPTIONS
Remote Condensing Units (one per barrel)

Refrigeration lines are not included and must be routed on location.

- 285112** Remote Condensing Unit, 1 Phase
- 285113** Remote Condensing Unit, 3 Phase

Dipping Cabinets

- DC4T-37-A** Four Compartment with Refrigerated Condiment Rail and Dual Temperature Control
- DC4T-37R-A** Four Compartment with Refrigerated Condiment Rail, Dual Temperature Control, and Reversed Hinges
- MDC4-37-A** Four Compartment
- MDC3-37-A** Three Compartment
- MDC2-37-A** Two Compartment

FEATURES

- Delrin® food grade plastic blades provide quiet operation and superior durability.
- Standard, divided and separated, dipper well helps prevent cross contamination between flavors for food allergy concerns.
- Service panel provides easy access to temperature controls.
- Each barrel has a separate refrigeration system and controls to run independently.
- Product stored at safe temperature in hopper for off-cycle periods and kept ready to freeze on-demand.

IntelliTec™ Control

- Lighted display communicates with operator for worry-free operation.
- Simple two-button operation for simple operation and cleaning.
- Constant monitoring for ease of troubleshooting.
- Precision-controlled refrigeration system.
- Tamper-proof controls for self-serve applications.

Continuous research leads to ongoing product improvements; therefore, these specifications are subject to change without notice and should not be used as installation specifications.

Approvals
Date

CC202A, CC303A CONTINUOUS FLOW FROZEN CUSTARD FLOOR MACHINES

DIMENSIONS

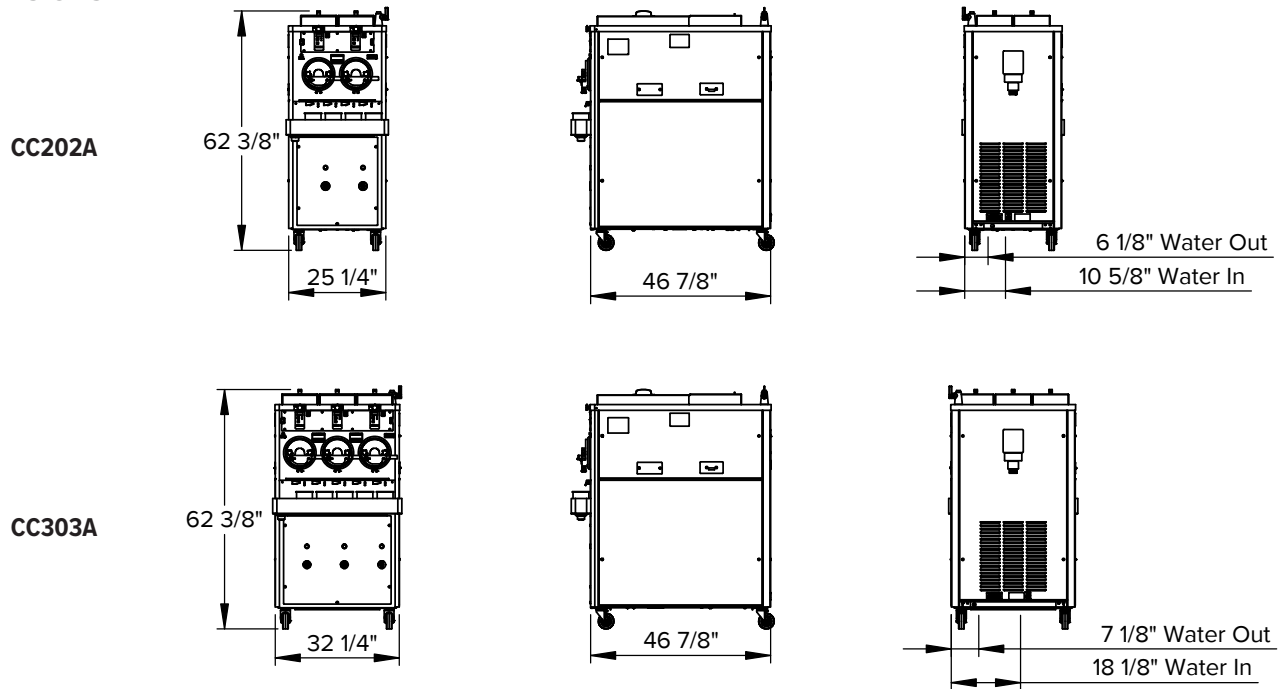

GENERAL SPECIFICATIONS

Model	Freezing Cylinder				Hopper				Drive Motor (hp)	Weight lb (kg)	Crated Weight lb (kg)
	Capacity gallon (L)	Compressor			Capacity gallon (L)	Compressor					
		Btu/hr	Refrigerant	Charge		Btu/hr	Refrigerant	Charge (oz)			
CC202A	Two 1.4 (5.3)	Two 9,000	R-448A	A/C & W/C: 8 lbs. per barrel	Two 8.8 (33.3)	2,700	R-134a	18	Two 3	1030 (467.2)	1100 (498.9)
CC303A	Three 1.4 (5.3)	Three 9,000		A/C Remote: 20 lbs. per barrel				Three 8.8 (33.3)			

- Indoor use only.
- Maximum ambient temperature: 100°F (37.8°C).
- Requires one dedicated electrical circuit per barrel and an additional circuit for the hopper refrigeration system (NEMA 5-15P hopper electrical plug)
- Water cooled units require: Units are self contained and require 1/2" N.P.T. water and drain fittings. Maximum water pressure of 130 psi. Minimum water flow rate of 3 GPM per barrel. Ideal EWT of 50°-70°F. They are charged with R-448A.
- Remote air cooled units require: One remote condensing unit (with compressor) per barrel. The machines ship from the factory with a dry nitrogen holding charge. The condensing units ship from the factory with 20 lbs of R-448A for up to a 50' line set. Add 1 lb of refrigerant for every 10' increase to the line set. Line set max 100'.
- Details on CAD Revit Symbols Libraries are available on stoelting.klccad.com

ITEM NUMBER SPECIFICATIONS

Model Number	Cooling	Phase	Volts	Hz	Circuit Ampacity (per barrel)	Overcurrent Protection Device (per barrel)
CC202-109A00SIR	Water	3	208-240	60	21A minimum	30A maximum
CC202-18A00SIR	Water	1	208-240	60	28A minimum	45A maximum
CC202-209A00SIR	Air Remote	3	208-240	60	9A minimum	15A maximum
CC202-28A00SIR	Air Remote	1	208-240	60	12A minimum	25A maximum
CC303-109A00SIR	Water	3	208-240	60	21A minimum	30A maximum
CC303-209A00SIR	Air Remote	3	208-240	60	9A minimum	15A maximum
CC303-28A00SIR	Air Remote	1	208-240	60	12A minimum	25A maximum



Service Information
 800-319-9549 (U.S. Toll Free)
 920-894-2293 (Outside the U.S.)
www.stoeltingfoodservice.com
www.vollrath.com