



Project:

Item Number:

Quantity:

0212 Single Flavor, High Capacity Floor Model Gravity Shake Freezer

Stoelting Foodservice Equipment

**0212 SINGLE FLAVOR, HIGH CAPACITY FLOOR MODEL GRAVITY SHAKE FREEZER**



0212



**DESCRIPTION**

Single flavor, high capacity, floor model gravity shake freezers have large freezing cylinder for high-volume dispensing and quick recovery. Ideally suited for high-volume operations offering high-capacity in a compact design. Front-mounted spinner standard. Spigot handle activates both the mixer and dispenser individually for fast service. Splash shield controls spray for fast and easy clean-up

**ITEMS**

Single Phase	Three Phase
<b>Air Cooled</b>	
<input type="checkbox"/> 0212-38B	<input type="checkbox"/> 0212-309B
<b>Water Cooled</b>	
<input type="checkbox"/> 0212-18B	<input type="checkbox"/> 0212-109B

**MIX INLET REGULATOR – (REQUIRED)**

One per barrel.

- 2149243-01** 2A 3/16" standard.
- 2204806** Adjustable.

**OPTIONS AND ACCESSORIES**

- 2204541** Hopper Lock Kit

**FEATURES**

- Unique, highly efficient auger design blends the entire contents of the freezing cylinder, delivering thick, smooth, and creamy shakes.
- Simplified operation, cleaning and maintenance: reduced number of internal barrel parts, one selector switch and auto-off-clean.
- Stainless steel auger, heavy duty speed reducer and 3/4 hp drive motor set the standard for long life dependability.
- High capacity refrigeration system with a 12,000 Btu/hr compressor produces volumes of shakes.
- Low mix warning light with electronic controls.
- Side-to-side air flow with removable air filter is quiet and efficient.
- Durable stainless steel exterior.



Every machine includes Stoelting's White Glove Service. One call does it all – customer service, technical service, parts or warranty information, installation, startup, sales, on-site service dispatch and much more. Available 24 hours a day, seven days a week year-round.

Continuous research leads to ongoing product improvements; therefore, these specifications are subject to change without notice and should not be used as installation specifications.

Approvals	Date

**0212 SINGLE FLAVOR, HIGH CAPACITY FLOOR MODEL GRAVITY SHAKE FREEZER**

**DIMENSIONS – IN (CM)**

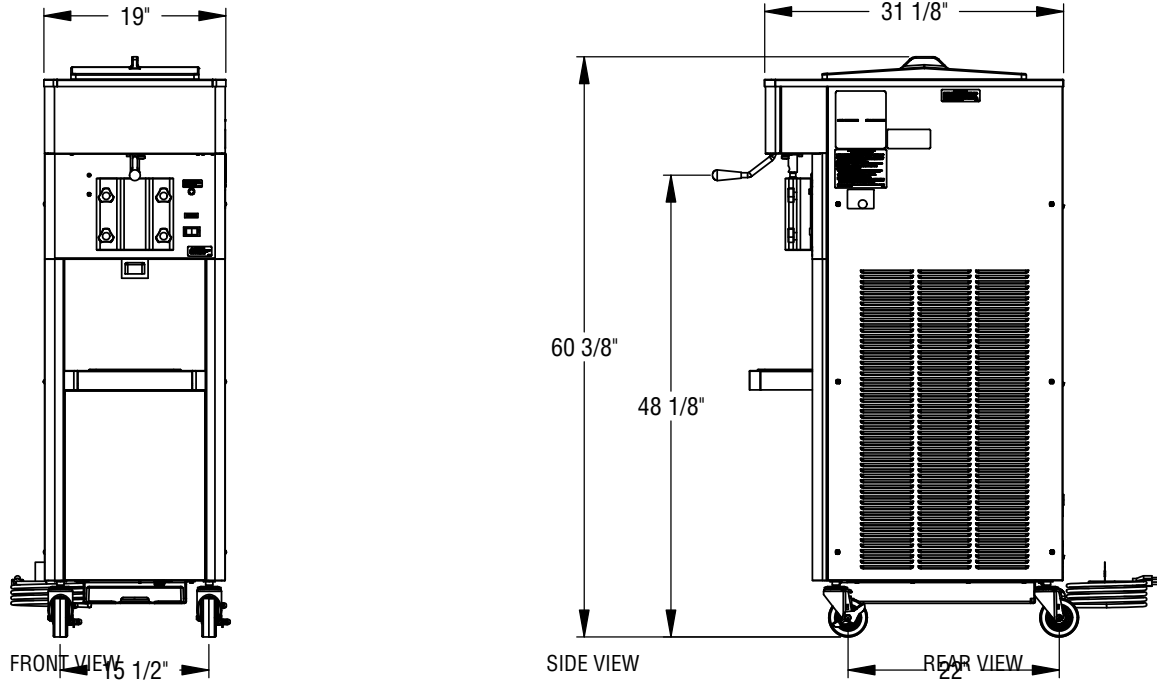

**GENERAL SPECIFICATIONS**

Machine	Freezing Cylinder			Drive Motor (hp)	Hopper Capacity gallon (L)	Weight lb (kg)	Crated Weight lb (kg)	Dimensions in (cm)		
	Capacity gallon (L)	Compressor Btu/hr	Refrigerant					Width	Height	Depth
0212	2 (7.57)	12,000	R-404A	3/4	6.5 (24.6)	315 (142.8)	410 (185.9)	19 (48.3)	60 3/8 (153.4)	31 1/8 (79.1)

- Requires a dedicated electrical circuit.
- Indoor use only.
- Maximum ambient temperature: 100°F (37.8 °C).
- **Air cooled units require:** Minimum clearance of 3" (7.6 cm) air space on all sides
- **Water cooled units require:** 3/8" N.P.T. water and drain fittings. Maximum water pressure of 130 psi. Minimum water flow rate of 3 GPM. Ideal EWT of 50°-70°F.

**ITEM NUMBER SPECIFICATIONS**

Item No.	Cooling	Phase	Volts	Hz	Running Amps	Plug
0212-38B	Air	1	208-240	60	10	NEMA 6-20P*
0212-309B		3			8	NEMA L15-20P*
0212-18B	Water	1			10	NEMA 6-20P*
0212-109B		3			8	NEMA L15-20P*

\*Power cord provided.



**Service Information**  
 800-319-9549 (U.S. Toll Free)  
 920-894-2293 (Outside the U.S.)  
 www.stoeltingfoodservice.com  
 www.vollrath.com