

Continuous Flow Counter-Top Frozen Custard Machine

CF101



- Quick-Freeze Technology™ minimizes size of ice crystals to ensure smoother, creamier product.
- Hold cycle keeps barrels at a safe temperature during off-cycle.
- Compact, counter-top model saves space.
- Easy to clean design ensures sanitary operation and ensures product is always fresh.
- Refrigerated hopper with independent temperature control maintains safe storage temperatures in any environment.
- Dual temperature control dispenses varied product types, such as Italian ice, sorbet, and frozen custard.
- IntelliTec™ control with lighted display provides simple two button operation.
- Super-sized condensing system provides high output even in high temperature conditions.
- Optional floor stand to create a “floor model” package, freeing up counter space and providing additional storage.
- Delrin, food grade plastic blades provide quiet operation and superior durability.



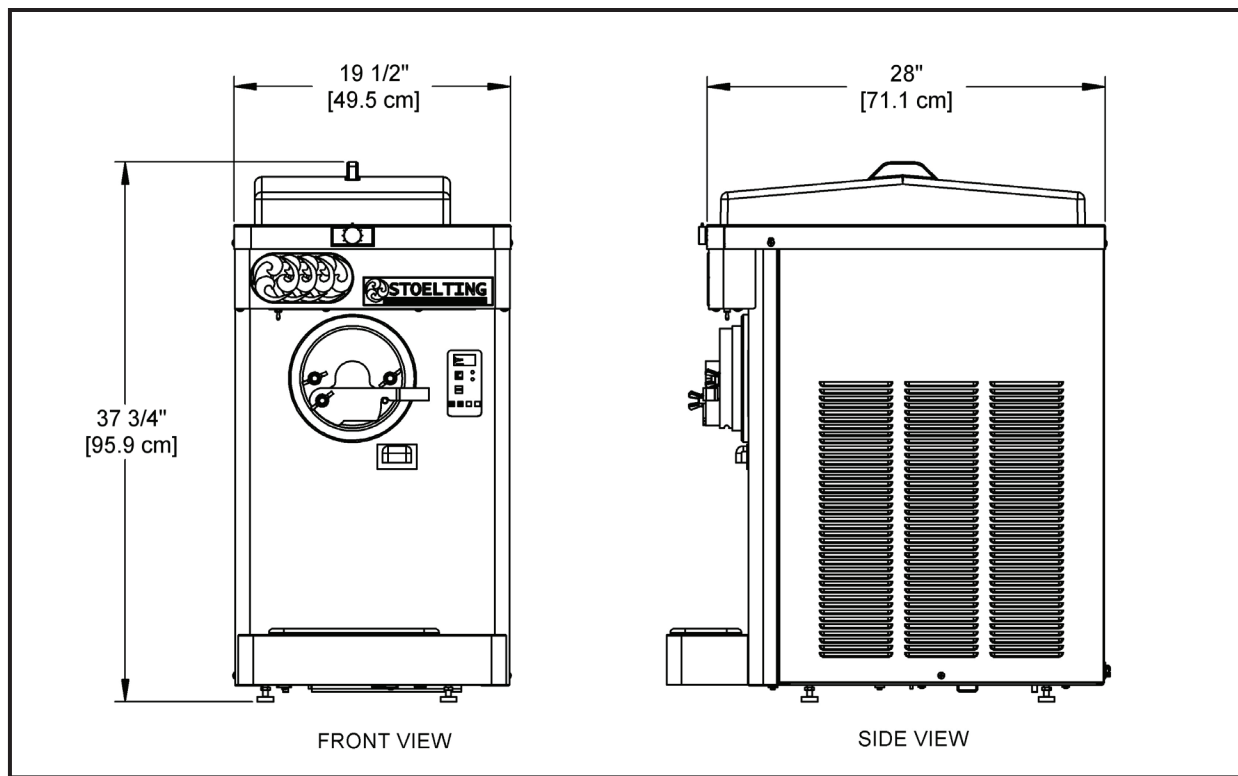

		CF101	
		Machine	with crate
Dimensions	width	19-1/2" (49,5 cm)	38-3/4" (98,4 cm)
	height	37-3/4" (95,9 cm)	28-3/4" (73,0 cm)
	depth	28" (71,1 cm)	43" (109,2 cm)
Weight		310 lbs (140,6 kg)	380 lbs (172,3 kg)
Electrical*		1 Phase, 208-240 VAC, 60Hz	
running amps		15A	
connection type		NEMA6-20P power cord provided	
Compressor		14,000 Btu/hr	
Drive Motor		1-1/2 hp	
Air Flow		Air cooled units require 6" (15,2 cm) air space at left and right sides and 10" (25,4) air space above the machine.	
Hopper Volume		5.4 gallon (30,28 liters)	
Freezing Cylinder Volume		0.8 gallon (3,03 liters)	

Continuous research leads to ongoing product improvements; therefore, these specifications are subject to change without notice and should not be used as installation specifications.

* Machine requires a dedicated electrical circuit.

Distributed by:



stoeltingfoodservice.com

Stoelting Foodservice Equipment
 502 Highway 67 • Kiel, WI 53042-1600
 920-894-2293 • 800-558-5807
 Customer/Technical Service: 888-429-5920
 E-mail: foodservice@stoelting.com

Certified, Listed and/or Recognized by:



ISO 9001:2008 Registered
 STMF-204 5/14